

NobleLight® | Infrared Emitters for Industrial Processes



Table of Contents

4 All About Infrared

6 The Golden 8 Infrared Emitter

10 Round Tube Infrared Emitters

12 Special Emitters

14 Applications



Excelitas – Decades of experience

With a background of many decades of experience, Excelitas develops, manufactures, markets and distributes a wide range of Noblelight infrared and ultraviolet emitters and components which find application in all important sectors and areas of industry.

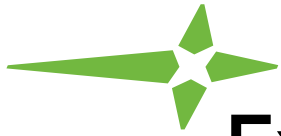

Excelitas - A Powerful Partner

Industrial heating processes must be constantly improved. A Noblelight emitter is always matched to the process - and not vice versa. Experience with thousands of heat processes, own application centers and competent and responsive people are the foundation to make heat processes faster, more energy-efficient, space saving and quality-orientated.

Modern production processes need intelligent heat

Today, there is hardly a product that has not come into contact with infrared heat at least once during its manufacturing process - and the tendency is rising. This makes it all the more important to select the right emitters for every application. Excelitas covers the full spectrum of technically usable wavelengths and helps to find the optimum light source for the individual process. Perfectly matched infrared emitters allow heating processes to be carried out at great efficiency and with the right amount of energy. Reliable and reproducible manufacturing processes save costs.

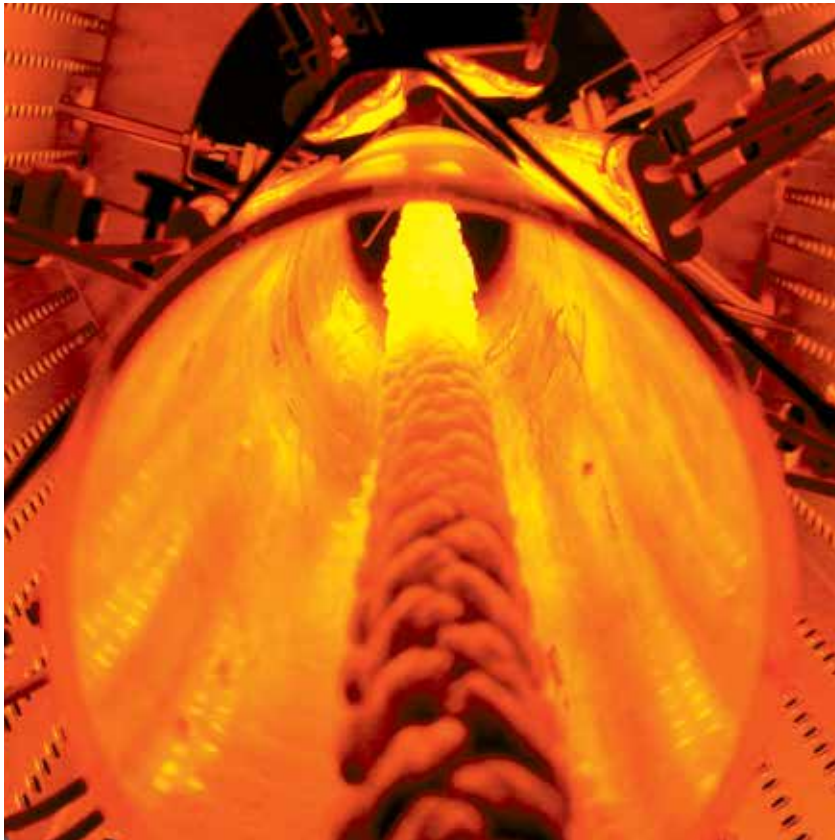

Infrared Intelligent Heat

Precise and Efficient

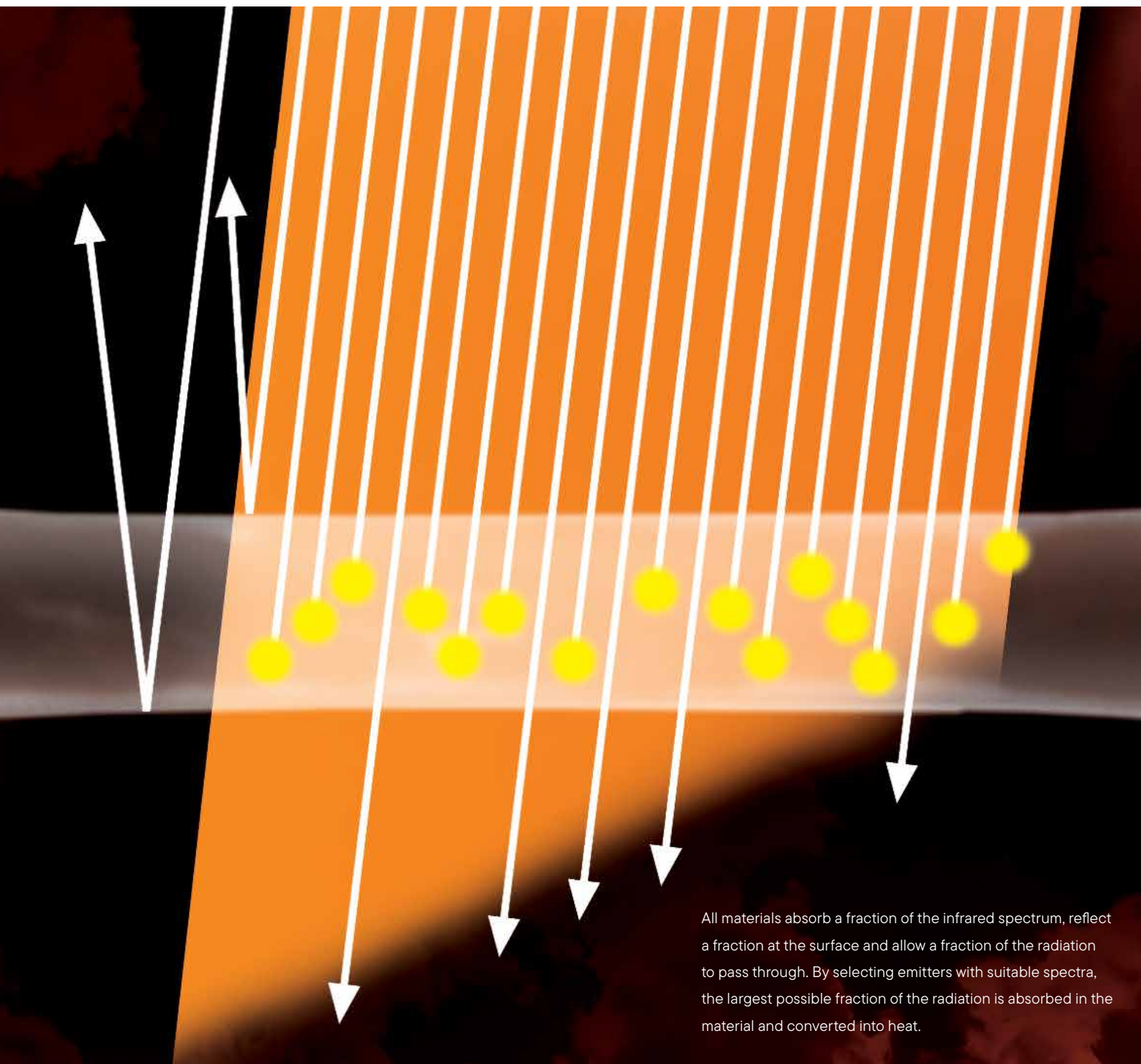

All materials absorb some of the infrared radiation, reflect some of it on the surface and allow some of it to pass through. By selecting emitters with suitable spectrum, as much of the radiation as possible is absorbed in the material and converted into heat.

Quartz glass infrared emitters frequently prove superior to conventional heating sources such as warm air, steam, ceramic, gas or metal emitters, because they transfer large amounts of energy very quickly and can be precisely matched to the product and the manufacturing step – the ideal heating process.

- Infrared radiation requires neither contact nor intermediate transfer medium
- Fast response times allow controllable heat
- Heat is applied precisely where and only for so long as it is required

Compared to hot-air ovens, this often means lower energy consumption, higher production speeds, less production space and better heating results.

To achieve successful process heating, it is important that the infrared emitter is carefully matched to the properties of the product to be heated in terms of its wavelength, its shape and its power output. Radiation which precisely matches the absorption characteristics of the product is quickly converted into heat in the product, without unnecessary heat being transferred to the surroundings. It also saves time and money if products can be transferred quickly for further processing after the heating stage.

The correct wavelength

Depending on the temperature of the heating element, an infrared emitter delivers distinctly different radiation at various wavelengths.

It is important to select the correct emitter for the product, as the wavelength has a significant influence on the heating process. Short wave radiation can penetrate deep into some solid materials and ensure a uniform through heating.

Medium wave radiation is absorbed mostly in the outer surface and predominantly heats the surface. Medium wave radiation is particularly well absorbed by many plastics, glass and especially water and is converted directly into heat.

PROPORTION OF HEAT				
	< 2 μm	2-4 μm	> 4 μm	Typical Emitter
600 °C	2,2%	37,2%	60,6%	Ceramic/Metal Sheathed
900 °C	13,0%	46,4%	40,6%	Standard Medium Wave
1200 °C	26,1%	46,9%	27,0%	Carbon
1600 °C	43,2%	40,1%	16,7%	Fast Response Medium Wave
2200 °C	62,5%	28,7%	8,8%	Short Wave
2700 °C	73,3%	21,0%	5,7%	Halogen/NIR
3000 °C	77,9%	17,6%	4,5%	High Power Halogen/NIR

CORRECT SELECTION OF HEATERS

If the temperature of the heating element of a short wave emitter is greatly reduced, medium wave infrared radiation can be emitted. However, the emitter power output then drops so much that economical heating is no longer possible. Consequently, for applications in the medium wave range, only medium wave emitters should be used, as these offer five times the power output at the same temperature.

Spectral radiation curves for different infrared emitters, normalized to the same power.

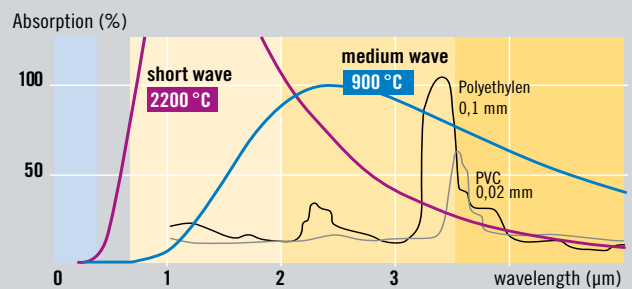
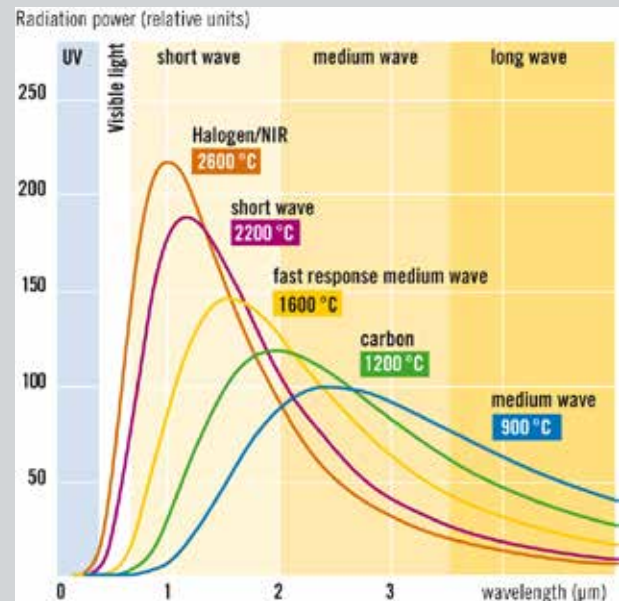

Plastics such as polyethylene and polyvinylchlorid are particularly good absorbers of infrared radiation in the medium wave region.

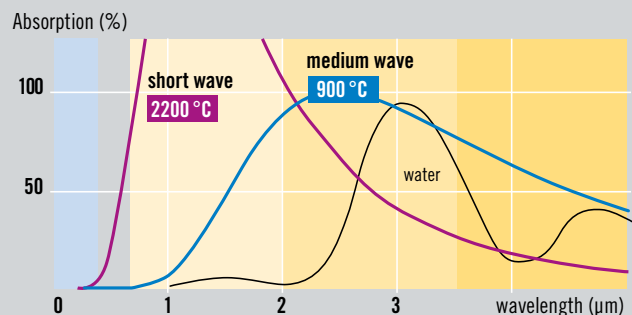

Water evaporates more quickly with medium wave infrared emitters as water absorbs radiation particularly well in this region.

Golden 8

Packaged Heat at the ready

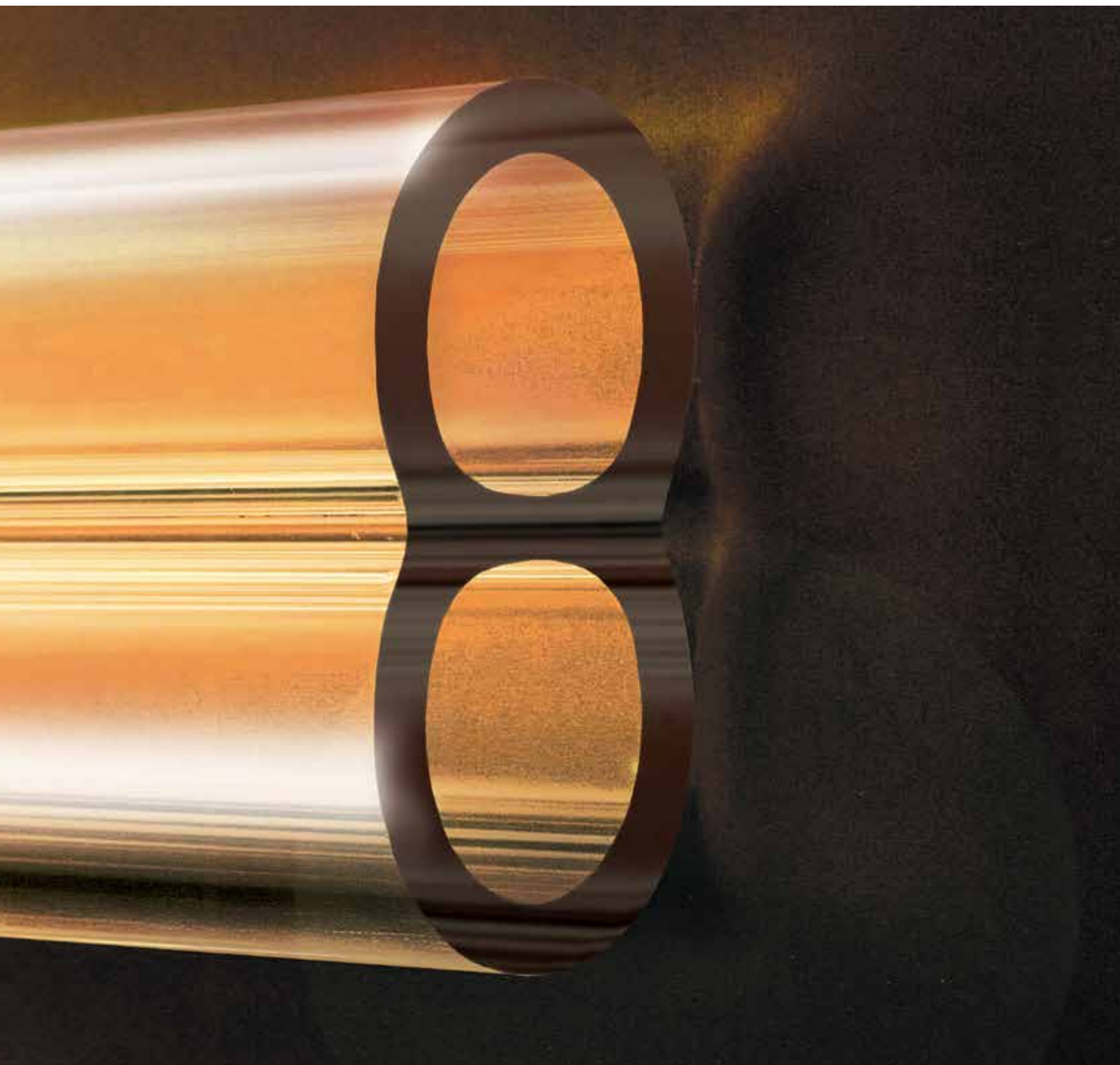



A reliable sign of competence and quality in infrared heating technology: the Golden 8!

The emitter cross-section of a twin tube in the shape of an eight, the golden reflector - the golden 8 stands for all our twin tube emitters and is the starting point for constantly new solutions for heating processes.

Quartz Glass

Golden 8 infrared emitters are manufactured from high quality quartz tubes. Quartz glass is very pure and provides good transmission and temperature resistance.

Twin Tube

The unique twin tube design offers high radiation power and very good mechanical stability – allowing emitters of lengths up to 6.5 metres. Wave lengths, dimensions and filaments are matched to requirements.

Gold Reflector

Noblelight infrared emitters with gold reflector can emit heat directly to the product. A gold coating on the infrared emitters reflects the infrared radiation. Consequently the infrared radiation impinging on the product is virtually doubled.

QRC® nano reflector

The evolution among reflectors is the QRC® (quartz reflective coating) nano-reflector, which consists of high-purity quartz material with which the quartz glass light tube is coated. QRC is resistant to aggressive environments, ideal for high-temperature processes or in a vacuum.

DESIGN OF THE TWIN TUBE EMITTER

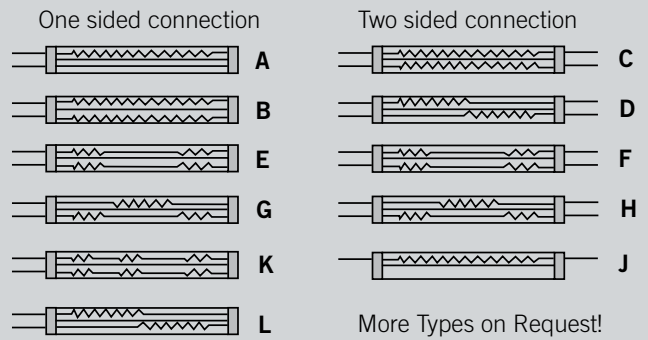

EMITTER CHARACTERISTICS

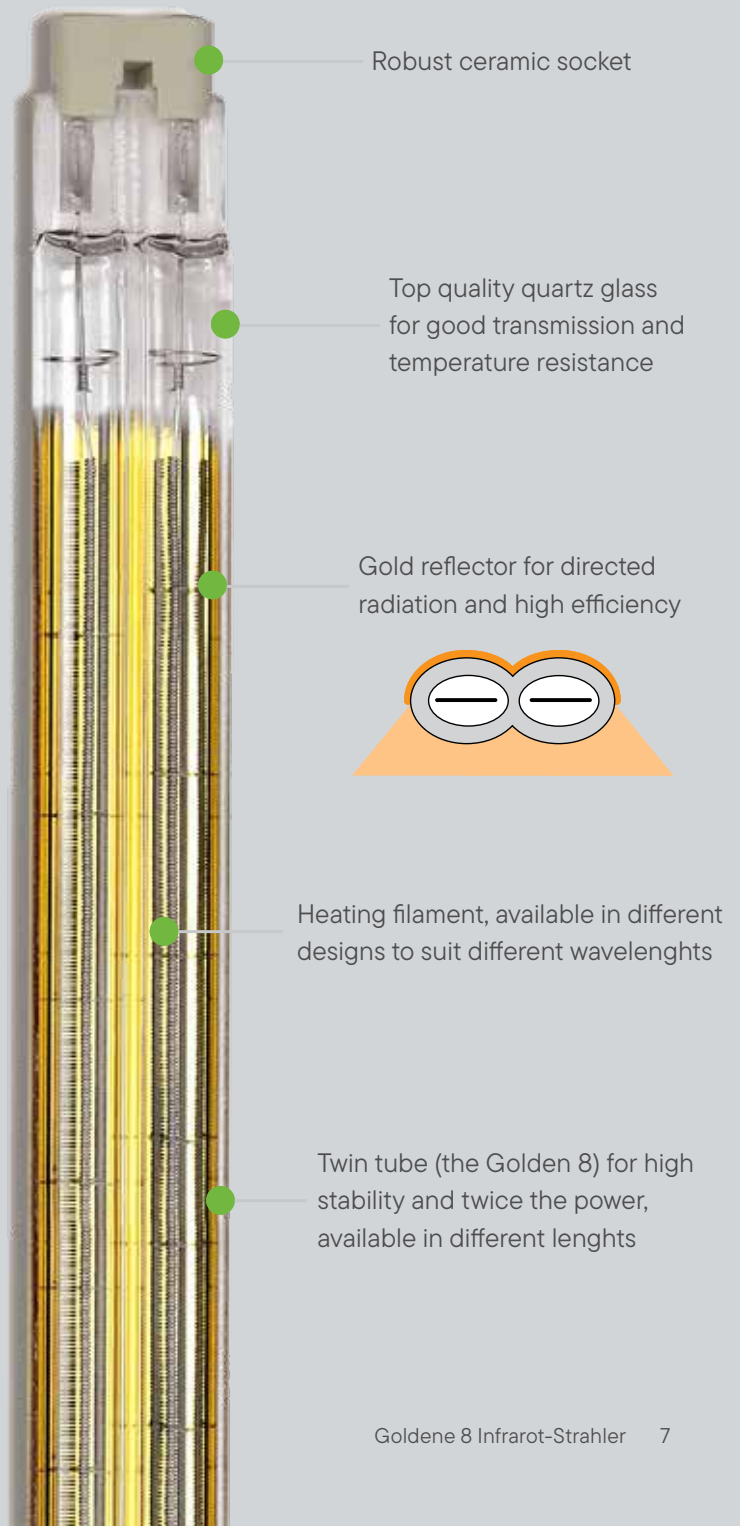

Carbon twin emitters flow and cure powder coatings efficiently



Infrared emitters need a flexible but firm holder so that they can operate correctly



Carbon Infrared Emitters CIR®

Carbon infrared emitters feature a unique heating filament design so that medium wave radiation offering very fast reaction times is possible. All Carbon infrared emitters CIR® offer high surface power densities and speed up heating processes at high efficiency.

Comprehensive tests have shown that Carbon emitters dry waterbased coatings significantly more efficiently than short wave infrared emitters. A Carbon infrared emitter may require only up to 30% of the energy for the same drying process as as conventional short wave infrared emitter. Moreover, many materials such as glass and plastics show a decided preference for thermal radiation in the medium wave region.

Carbon Emitters

combine medium wave radiation at high Watts density with response times in terms of seconds.

Short wave twin tube

are similar to halogen emitters in terms of spectrum but offer significant benefits in terms of lifetime, strength and durability.

Fast response medium wave emitters

are twin tube emitters with a spectrum between those of short wave, and medium wave emitters.

Medium wave emitters

distinguish themselves with their high cost-efficiency, stability, and operating life.



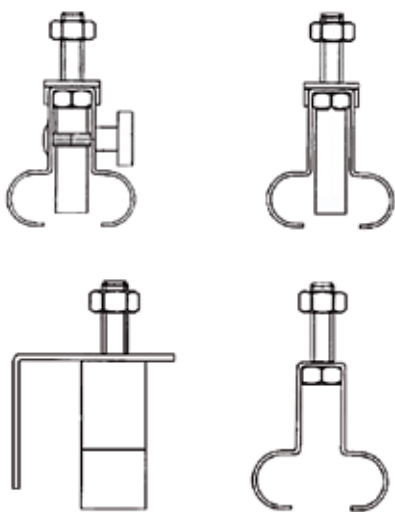
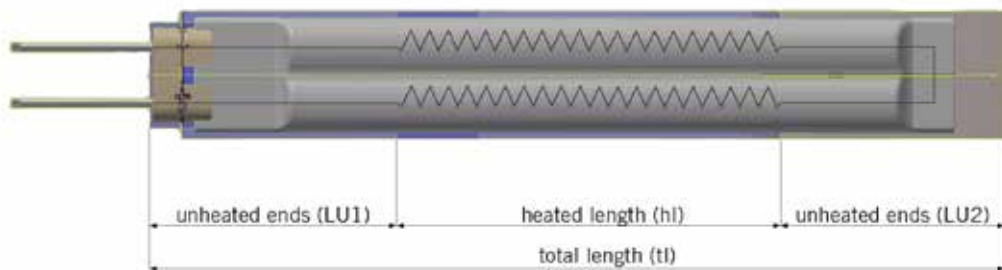

STARTING CURRENT

When switching on an emitter, it can reach peak current in a very short time. This needs to be considered when designing your system. For further information please contact us!

Emitter type	Element temperature	Switch-on current factor
SW	1800-2400°	12-17
FRMW	1400-1800°	10-13
MW	800-950°	1-1,05
Carbon	1200°	0,8

TECHNICAL DATA

Twin tube emitter	Short wave	Fast response medium wave	Medium wave	Carbon
Max. specific power W/cm	<200	80	18/20/25*	60
Max. heated length mm	6400/2400*	6400/2400*	1500/2000/6500*	3000
Cross-section mm	34x14 23x11	34x14 23x11	18x8 20x10 33x15	34x14
Filament temperature °C	1800-2400	1400-1800	800-950	1200
Peak wavelength µm	1.0-1.4	>1.4	2.4-2.7	2
Max. surface power density kW/m ²	200	150	60	110
Response time s	1	1-2	60-90	1-2

* Depending on cross-section

Round Tube Emitters



ROUND TUBE STANDARD EMITTERS

Power [Watts]	Voltage [Volts]	Heated Length [mm]	Total Length [mm]	Diameter [mm]	Item Number
Carbon round tube emitter (without gold reflector)					
1000	57,5	500	430	19	45132877
2000	115	800	730	19	45132876
Carbon round tube emitter (with gold reflector)					
1000	57,5	1300	1420	19	45132828
2000	115	1500	1600	19	45132833
Short wave round tube (without gold reflector)					
500	115	120	225	10	80163522
Short wave round tube (with gold reflector)					
500	115	120	225	10	80132237

For many applications, an infrared emitter consisting of just a heating element in a quartz tube is the perfect choice. Such emitters are, in the main, shorter than twin tubes. Obviously, round tube emitters can also be fitted with a gold reflector

Halogen short wave (NIR) radiation

is provided by halogen infrared emitters with spectrum in the near infrared region, a maximum power density of 1 MW per square meter and very fast response times. These emitters are manufactured in top quality quartz glass and are conventionally round tubes. An optional gold reflector can virtually double the amount of effective radiation drop out on the product.

Halogen Short Wave/NIR

Carbon round tube



TECHNICAL DATA

Carbon round tube IR emitter	
Max. specific power W/cm	30
Max. heated length mm	1500
Cross-section mm	19
Filament temperature °C	1200
Peak wavelength µm	2
Max. specific power kW/m ²	85
Response time s	1-2

CLAMP & HOLDING SPRINGS

Every infrared emitter needs a clamping- and holding-spring to ensure that the emitter is held correctly. For further information please contact us!

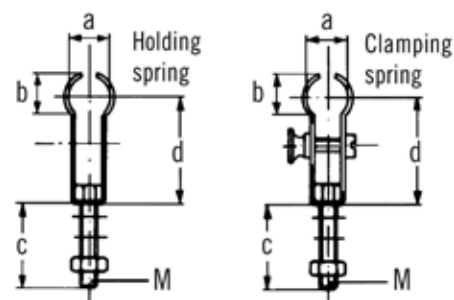

Special Emitters

Heat precisely where it's needed

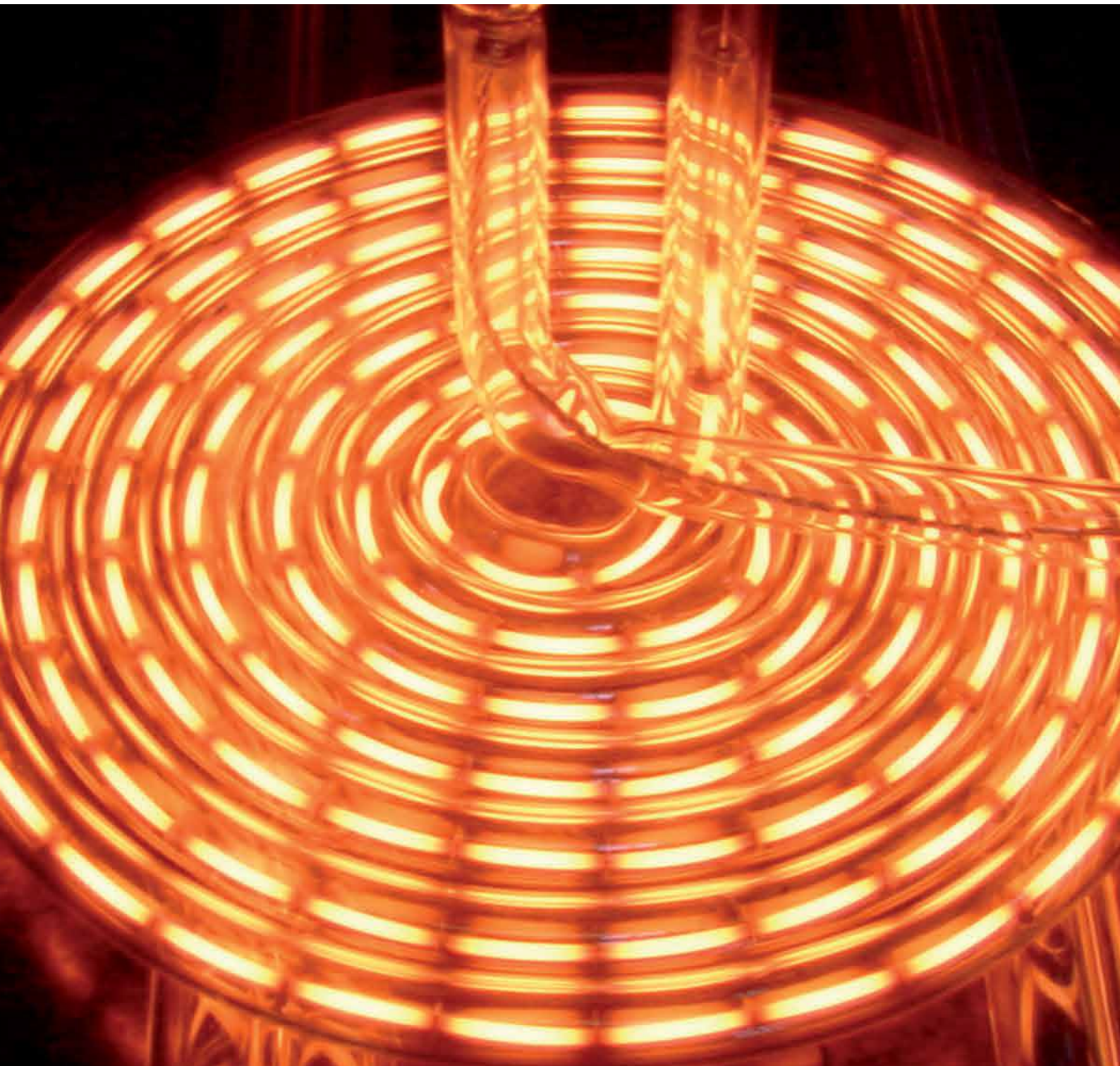

Edges, corners and contours are followed exactly and heated in a focused manner



To rivet two parts together, an omega emitter only needs to heat rivets, not the entire part



Noblelight infrared emitters are precisely matched. They heat large surfaces as well as small edges and complex geometry work pieces. The potential to switch the infrared emitters on and off in seconds allow significant savings in both energy and operating costs. Energy losses to the environment are incredibly small and production process times can be reduced or more parts can be produced in the same time.

Contoured Emitters

Individually shaped emitters can follow work piece corners and edges to allow any required bending process or for the local activation of adhesives.

Small Surface Emitters

Short wave emitters heat complex geometries so that two surfaces can be joined without adhesive.

Omega Emitters

Circular short wave emitters for hot staking. With heat up and cooling times in terms of seconds, very short process times can be realised.

QRC® Emitter

Many sensitive heating processes run faster, more efficiently and more stable when infrared emitters with the QRC reflector are used. The nano reflector has very good heat resistance

and is also resistant to acids, alkalis and other aggressive substances. Consequently, emitters with this reflector can be used even in manufacturing processes where the manufacturing plant requires regular cleaning with corrosive cleaning agents. Also QRC heaters can be bent or formed to fit exactly to edges or contours of a product.

INFRADRY®

Infradry modules combine infrared heat and air management very efficient. Intensive infrared heat with controlled air introduction and extraction ensures effective drying.

Infradry combi allows an air extraction within the infrared emitter field for the first time. In contrast to conventional dryers, the moisture is removed directly in the process area.



Application Center

Practically-based Support



There is scarcely a product manufactured which does not pass at least once through a heating process during its manufacture. Coatings are dried, adhesives activated and plastics heated before forming.

More efficient heating processes are achieved by better energy utilization. As a result, heating is shorter, in terms of time or in terms of space requirement, so that the complete production plant is more cost-efficient.

You have to understand the different applications to exploit infrared heating productively. Excelitas has set up Applications Centers to increase its knowledge through investigations and tests and to share experiences with customers. We offer all customers the opportunity to clarify important questions in a practical manner:

- Can my process be optimized with infrared?
- Is my material suitable for infrared?
- Which emitters are best suited to my process?
- How should these emitters be designed?
- How can they be integrated into my production process?

Application examples:

Coating more efficiently

Competition is forcing the coating industry to reduce energy costs and shorten production times. An upstream infrared module brings the product to the right temperature, which the existing dryer then maintains for as long as necessary. An infrared heating zone upstream of an existing dryer helps to maintain and often even increase product throughput.

Better processing of foodstuffs

Carbon infrared emitters can be used to brown the breadcrumb topping or other garnishing on ready meals, without cooking the meal through. Carbon emitters prove more efficient than conventional heating sources, saving energy and valuable production space, as well as minimizing maintenance costs.

More efficient car manufacture

Crease-free seat covers, matching panelling, precisely deburred steering wheel caps and cleanly welded containers for wiper fluid or brake fluid - infrared emitters are precisely adapted to the material and process and thus heat in a targeted and precise manner. This helps to automate industrial processes, saving time, energy and costs. Batteries require electrodes. Metal foils are coated and dried for this purpose. Infrared systems and CAE simulations optimise the processes required for efficient production.



GOLDEN 8 STANDARD EMITTERS

	Power [Watts]	Voltage [Volts]	Heated Length [mm]	Total Length [mm]	Emitter type	Item Number
MEDIUM WAVE	500	230	300	400	B	09752439
	1000	230	500	600	B	09755167
	2000	230	800	900	B	09755054
	2500	230	1000	1100	B	09755255
	3250	230	1300	1420	B	09753187
	3750	230	1500	1600	B	09754585
	4100	400	1700	1800	B	09754863
	4500	400	1800	1920	B	09754783
	5750	400	2300	2400	B	09756083
	6250	400	2500	2600	B	09753874
SHORT WAVE	2500	230	1200	1300	C	09753923
	3000	400	1000	1100	A	09751720
	600	115	80	145	B	09751713
	1500	230	200	300	B	09751751
	1200	230	340	405	B	09751741
	3000	400	500	600	B	09751740
	3000	400	500	600	B	09751340
	3000	230	500	650	C	09751761
	4200	230	700	850	C	09751765
	6000	400	1000	1150	C	09751750
CARBON	7000	400	1300	1450	C	09751731
	3600	230	600	745	B	80124854
	4000	230	700	845	B	80009221
	6000	400	1000	1145	B	80034180
	6600	400	1100	1245	B	80133767
	7500	230	1250	1400	C	80082354



+49 (6023) 405-9600

Industriestraße 15
63755 Alzenau
GERMANY

excelitas.com
hng-infrared@excelitas.com
hng-contact@excelitas.com

For a complete listing of our global offices, visit www.excelitas.com/locations

© 2024 Excelitas Canada Inc. OmniCure®, StepCure® and Intelli-Lamp® are registered trademarks and Intelli-Tap™ is a trademark of Excelitas Canada Inc. The Excelitas logo and design are registered trademarks of Excelitas Technologies Corp. All other trademarks are the property of their respective owners, and neither Excelitas Technologies Corp., its affiliates or subsidiaries, or any of their respective products, are endorsed or sponsored by or affiliated in any way whatsoever with those organizations whose trademarks and/or logos may be mentioned herein for reference purposes. Excelitas Canada Inc. reserves the right to change this document at any time without notice and disclaims liability for editorial, pictorial or typographical errors.

XNG Productbrochure 2026/03